

EC Websites Development 2022 Assignment 2

(Due Date: Oct 5, 2022)

INSTRUCTIONS : This assignment consists of 6 questions. Each question has multiple parts. You have to answer all of them. The answers of the questions have to be written in English. You need to edit the answers by a word processing software, like MS WORD or Pages.

Submit the answer file to the following Gmail account before October 5, 2022: 00:00. That is to say, your answer file has to arrive the Gmail account on or before October 4, 2022. Note that the email heading and the filename of the answer file have to be conformed to the following formats.

Email: johnsum.nchu@gmail.com
Email heading: ECWD2022_Assignment02_studentID
Filename: ECWD2022_Assignment02_studentID

If your answer file is edited by Pages, a word processing software running on MacOS, please convert your file in PDF format.

Reminder: Please double check your writing to ensure that there is no any obvious grammatical mistake or spelling mistake. If there is, your assignment will get zero score.

Contents

1 Basic Software Architecture for a Website	2
2 Multi-Tier Software System Architecture	2
3 Client-Server Model	6
3.1 Internet as a huge distributed server	6
3.2 Other client-server systems	8
4 Business Processes Regarding Online Shopping	8
4.1 Order placement and payment	8
4.2 Order fulfillment	10

1 Basic Software Architecture for a Website

To understand the basic software architecture of a website, it is better to take a look on the steps how does the browser in a customer's computer get the web page from a website.

- (a) Customer accesses the homepage of a dotcom by keying the URL of the dotcom (say `www.abc.com`) on the address bar of the browser in his/her computer at home. The request for the homepage file will then sent to the web server of the dotcom via Internet. (Once the customer has pressed the 'Enter' button, the computer will then send a message in a form of a packet to the Internet. The Internet will route the message to the computer with the destination IP address. Figure 1 shows the interactions among the browser, the operating system, the network card and the Internet for this message transfer process.)
- (b) Once the message has arrived the web server on the dotcom side, the web server will thus search and get the homepage file (say `index.html`) from the file system in the server.
- (c) If information from the database management system (DBMS) has to be added, the web server and or the webpage server will access the DBMS for the information.
- (d) The corresponding webpage file (in a form of text message) to be returned is generated and subsequently sent back to the customer via the Internet.
- (e) Once the webpage file has arrived the customer's computer, the browser renders from the webpage file and displays it via the browser to the customer.

Therefore, the basic software architecture for online shopping consists of four components, namely (1) browser, (2) web server, (3) DBMS and (4) file server for the webpage files. Figure 2 shows an exemplar software architecture for a website.

Question 1

- (a) As all the software of a website have to be installed and running on multiple computers, which operating system(s) the computers should be installed? In other words, which operating system(s) you will install for the computers to support the website? You need to give reasons explaining why.
- (b) Similar to Part (a), which web server would be suitable for a website? You need to give reasons explaining why.
- (c) Which DBMS would be suitable for a website? You need to give reasons explaining why.
- (d) If it is expected that a customer will access the website via his/her iPhone or Android phone, what will be your answers for Part (a) to Part(c)?

2 Multi-Tier Software System Architecture

For the architecture as shown in Figure 2, it is usually called a multi-tier software system architecture. For any web-based application system, it must consist of two major modules including a

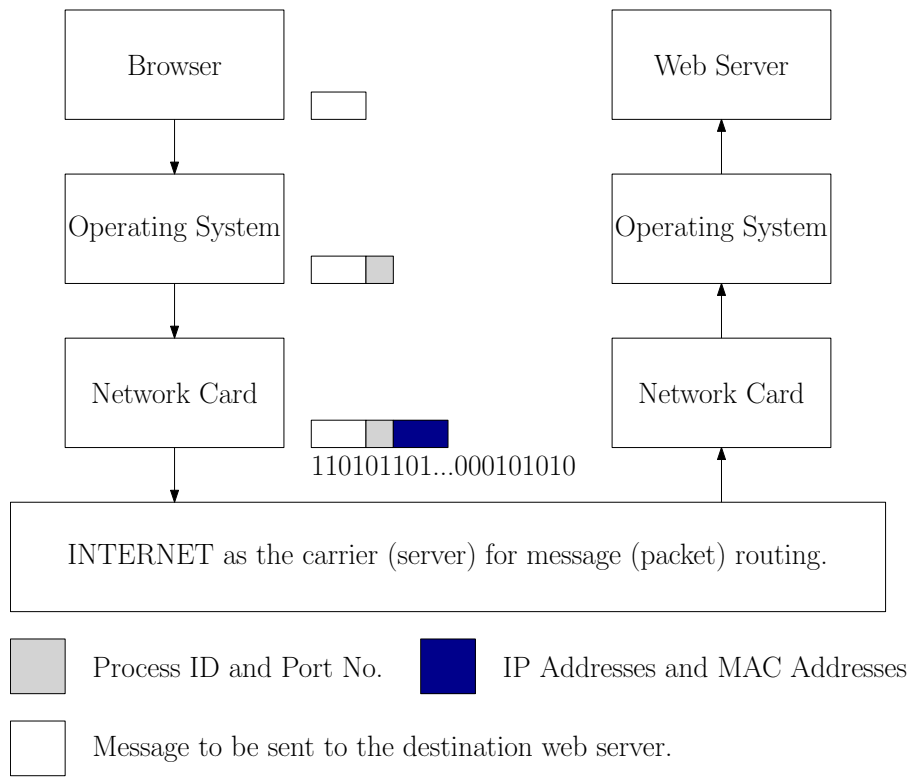
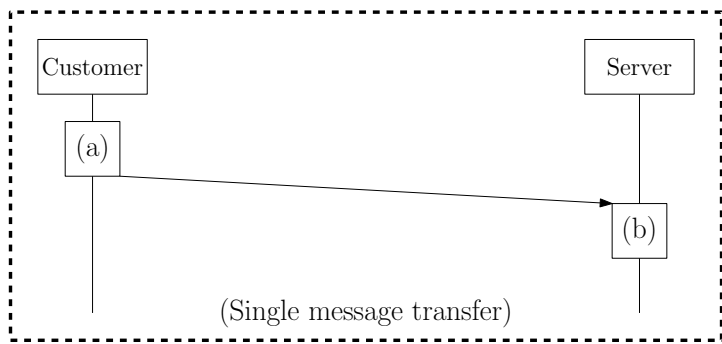

Figure 1: Message transfer process. (Top) Once the customer has pressed the 'Enter' button, the computer will then send a message in a form of a packet to the Internet. The Internet will route the message to the computer (i.e. the web server) with the destination IP address. (Bottom) The detail steps for transferring a message from the browser (as a process) in the customer's computer and the web server (as a process) in the web server computer. The message composed by the browser could be treated as a *text command* for the web server to complete a certain tasks. Normally, the web server will need to return the results to the browser once the tasks have been done. The role of the Internet just likes a network of postal offices which delivers letter from a sender to his/her receiver.

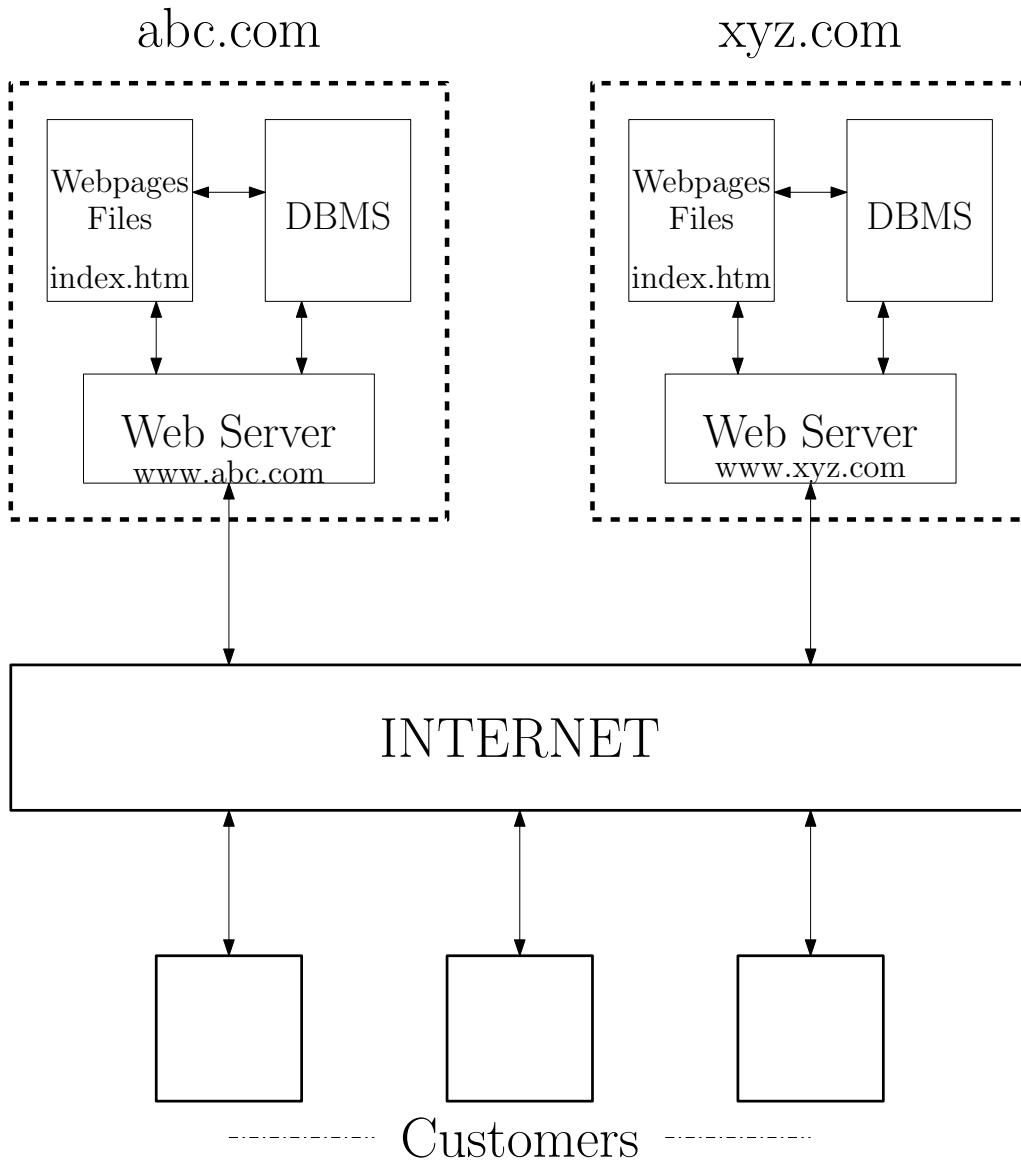

Figure 2: Basic software architecture for online shopping. Note that, in contrast to Figure 1, operating system and the network card are usually not included as part of the software architecture. But, one should realize that they are working all time in a computer to support this software architecture.

Basic Web-System Architecture: Multi-Tier

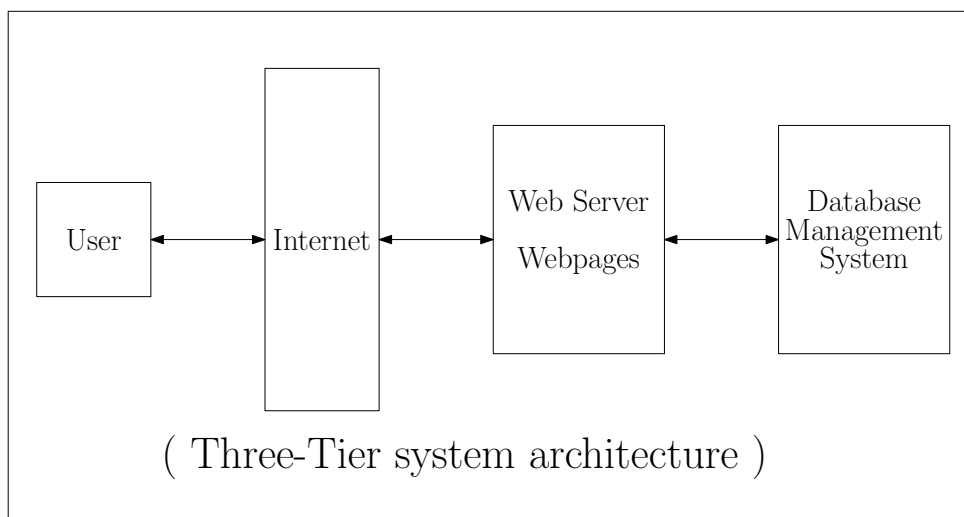

Figure 3: Multi-Tier software system architecture. The components in the system are software. Each component corresponds to a tier.

website (big module) on the dotcom side and a browser (small module) on the customer side. The website normally refers to a module consisting of multiple software systems. Like the one shown in Figure 2, the website consists of two software systems, namely the web server and the DBMS.

System architecture depicts the *logical dependence* among the software components in a web-based application system. The browser on the customer side is one tier, the web server is another tier and the DBMS connected to the web server is another tier. Internet is the medium for the connection between the browser on the customer side and the website on the dotcom side.

For a small scale website, like `john.digi-pack.io`, all the webpage files and the web server are located in the same (physical) machine. Thus, the architecture of `john.digi-pack.io` is simply a 2-tier. For other applications, the web server might have to interact with multiple database management systems and multiple file systems. The system architecture of these websites might be 4-tier and even 5-tier.

No matter how many tiers, one should be noted that each browser only interacts to the web server. Their interactions (i.e. messages passing back and forth) follow the rules defined by the hypertext transfer protocol (HTTP) or hypertext transfer protocol secure (HTTPS). The web server acts as the doorman of a website.

Question 2

- (a) Web server and DBMS are essentially two software. It is thus possible to install both software in a single computer and the computer is also called a server. Sometimes, a computer might be installing with a web server, an email server and a FTP server. The computer is again a server. Describe under what condition(s) both web server and DBMS should be installed in a single computer or two computers.

- (b) Search over the Internet for the concept of an architecture called 'server cluster' or 'cluster of servers'.
- (c) Describe the reason(s) why the architecture 'web server cluster' is implemented in many websites, like `google.com`, `bin.com` and `youtube.com`.
- (d) Today, many websites are developed and running in a cloud platform, like Amazon Web Service (AWS) or Google Cloud. Explain the reason(s) why so many firms prefer to put their websites on the cloud.

3 Client-Server Model

Client-server model is an important concept to support multi-user access for a single resource (respectively application). For the case of EC website, the web server is the software running in a single computer to handle (to coordinate) all the interactions from multiple customers. The browser running in a customer's computer is considered a client. The web server is clearly the server. The interaction between the browser and the web server is a client-server interaction. Figure 4 shows the idea behind website access.

Client-server model does not exist only in the situation where multiple customers access a dotcom website. This model has also been manifested in many situations. For instance, public transportation corporations provide transportation services for the citizens in a city. Each corporation is thus a server and the citizens are the clients of the corporation. In banking industry, each bank is a server. Each personal customer or corporate customer is a client of the bank.

One drawback of client-server model is that the system being implemented is centralized coordinated by the server. The server might have very high burden. Nevertheless, the server could be the target to be attacked. Hacker could attack the server to paralyze a website.

Question 3

- (a) In a personal computer, is it possible to find an example in which client-server model has already been realized? What are they?
- (b) Comment if there is any difference between the ideas of client-server model and resource sharing.
- (c) (*) What is(are) the key difference(s) between client-server model and peer-to-peer model?

3.1 Internet as a huge distributed server

It should be noted that the data communication via Internet follows the client-server model. Once a computer would like to send a data/message to another computer, both the sender computer and the destination computer are clients. The sender computer will compose a message and send it to the Internet. The Internet routes the message to the destination computer with the corresponding destination IP address. Internet is indeed a huge distributed server serving the computers connecting to it for their messages transfer.

Client-Server Model (Architecture)

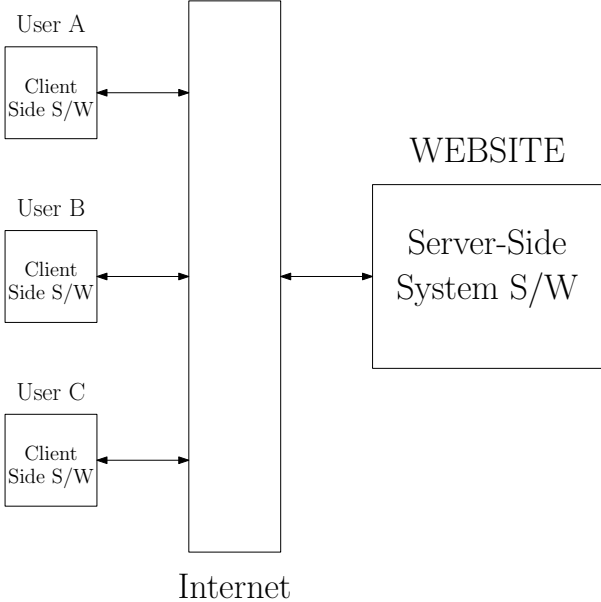

Client-Side S/W: Browser, iOS Apps or Android Apps, and others.
Server-Side S/W: Web server, website programs, webpage files, and others.

Figure 4: Client-Server model. (1) The user interacts the client side software to compose a request-message to be sent to the Internet. (2) The request-message is then routed to the server side system. (3) Once the request-message has arrived the server side system, the server will do certain tasks to accomplish the request. (4) The server thus compiles the results as a result-message. (5) The result-message is then sent via the Internet to the client side software.

3.2 Other client-server systems

As a matter of fact, there are many client-server systems which have been appeared around us. Below lists a few of them for your reference.

- A customer of a bank is a client. The bank acts as a server providing services to its customers.
- Public transportation system, like train system or bus, acts as a server to serve the citizens (i.e. clients) for transportation.
- City government acts as a server to serve the citizens (i.e. clients) for their public administration.

Clearly, the interactions between the clients and the servers in these client-server systems are very different from the ways that a computer interacts with the Internet. They involve a lot of human activities, rather than electronic messages.

4 Business Processes Regarding Online Shopping

For any EC firm, her profit can only be made after a transaction has been completed. A transaction starts at the moment when a customer has placed an order and ends up at the moment when the customer has got the items purchased.

4.1 Order placement and payment

Owing to accomplish an order placement, a website has to be ready for the customer to access and place an order. Besides, the website is needed to provide a few common payment methods for the customer to settle the payment.

In the following, the steps in which a customer needs to go through in an order placement will be listed. To start with, we need the following assumptions on moment when the customer is in order placement process.

- The customer has already invoked a browser in his/her computer and entered the URL of the dotcom on the address bar of the browser.
- The customer's computer and the dotcom website have already been connected to the Internet.
- The customer has already registered a member account on the dotcom website.
- All the necessary information for the customers have been available on the website.
- Both the customer and the firm have their bank accounts for the payment transfer.
- The website has a module interacting with at least one electronic transaction system (ETS) provided by a financial institute.
- It is assumed that the customer will not cancel the order after the order has been successfully placed.

Order Placement Process (Between the customer and the website)

Step 1: (Customer login.)

1.1: Customer enters via the browser an account and its password.

1.2: The account name and the password are sent to the website.

Step 2: 2.1: The website checks if the password is correct.

If it is correct, the next step goes to Step 2.2.1.

If it is incorrect, the next step goes to Step 2.2.2.

2.2.1: The website returns to the customer the default webpage for online shopping. The next step goes to Step 3.

2.2.2: The website returns to the customer an error page.

The next step goes to Step 1.

Step 3: 3.1: Customer browses the product catalogue and/or search for the products of interest.

3.2: Customer selects the items to be purchased.

3.3: Customer submits the order.

Step 4: Website returns the order information for confirmation.

Step 5: Customer confirms the order to the website.

Step 6: Website returns to the customer the payment/delivery page.

Step 7: 7.1: Customer selects a payment method and a delivery method.

7.2: Customer enters the credit card information for payment.

7.3.1: Website acts on behalf of the customer to request the ETS for payment transfer.

7.3.2: The ETS transfers the amount from the customer's bank account to the firm's bank account.

7.3.3: Once the payment has been received, the firm's bank informs the accounting information system of the firm for the settlement.

7.3.4: The bank of the customer informs the customer about the payment transfer.

Step 8: 8.1: Website interacts with an ETS to confirm the settlement.

8.2: Website returns the receipt in a form of webpage.

Step 9: 9.1: Website saves the order information in the DBMS.

9.2: Website informs the logistic center for order fulfillment.

Step 10: Customer logs out the account.

The above steps only show a rough outline of an order placement process. Many technical details have been omitted.

- The method how the website informs the logistic center for the new order has not been specified.
- The technical detail on the graphical design of those web pages has not been elucidated.

- The method how the website interacts with an ETS to confirm the settlement has not been mentioned.
- Dependent on the firm policy, the order information might have to be saved in multiple DB management systems, such as the accounting information system and the customer relationship management system. For the sake of presentation, this part has not been explored here.

Note that the above order placement process is applicable to both the conditions that (1) the customer accesses the website via a computer and (2) the customer accesses the website via a cell phone.

Question 4

- Part (a) Apart from the customer and the website, three additional systems the website have to interact with. What are these systems?
- Part (b) To ensure that the information about the products is available on the website, some workers in the firm have to update the information. Which department(s) the workers should be affiliated?
- Part (c) Follow Part (b), what should the workers do so as to ensure that the product information is most updated?
- Part (d) Roughly estimate how much time the above order placement process could be completed.
- Part (e) Is it able to simplify the order placement process as depicted above? If your answer is yes, state your new process.

4.2 Order fulfillment

Once a customer has successfully placed an order, the order information will then be saved in some DB management systems. Clearly, the order information must be stored in an information system in the logistic center. Before the detail steps in the order fulfillment process are depicted, a few assumptions have to be made.

- An information system has been developed and connected to the website for a worker in the logistic center to get the details of the new orders.
- The purchased items are available in the logistic center for packaging and delivery.
- A user account in the logistic center information system (LCIS) has been logged in and no worker is allowed to log out the account.
- The 3PL information system (3PL IS) has already been connected to the Internet. Moreover, the 3PL IS has been developed to interact with the website.

Order Fulfillment Process

(LC worker: logistic center worker.)

(LCIS: Logistic center information system.)

(3PL: Third party logistic.)

(3PL IS: Third party logistic information system.)

Step 1: 1.1: LC worker gets a new order information from the LCIS.

1.2: LC worker prints all the adhesive labels for the new order.

1.3: LC worker taps the labels on a parcel box.

Step 2: 2.1: LC worker collects the ordered items.

2.2: LC worker packs the items in a parcel box and seals the box.

2.3: LC worker puts the parcel box in the area for delivery.

2.4: LC worker confirms via the LCIS for the job completion.

Step 3: 3.1: LCIS informs the 3PL IS notifying for the new delivery.

3.2: 3PL IS informs a 3PL worker the new delivery.

Step 4: 4.1: 3PL worker collects the parcel box.

4.2: 3PL worker confirms via the 3PL IS for the box collection.

Step 5: 3PL worker delivers the parcel box to the customer.

Step 6: 6.1: Customer confirms via the 3PL IS the receiving of the parcel.

6.2: 3PL IS updates the status of the delivery as completion.

Step 7: 3PL IS informs the website for the completion of the order.

Similar to the order placement process, the above steps only show a rough outline of an order placement process. Many technical details have been omitted. To accomplish the completion of the order placement and order fulfillment processes, a number of systems have to be working together. Figure 5 shows the software and systems to be involved in these processes.

Question 5

- (a) How many parties (either a human or a system) are involved in this order fulfillment process and who are they?
- (b) Roughly estimate how much time the above order fulfillment process could be completed.
- (c) Is it able to simplify the order fulfillment process as depicted above? If your answer is yes, state your new process.

Question 6

In the above descriptions about the order placement process and the order fulfillment process, a number of assumptions (equivalently, conditions) have been made. It is clear that maintaining such conditions might not be easy.

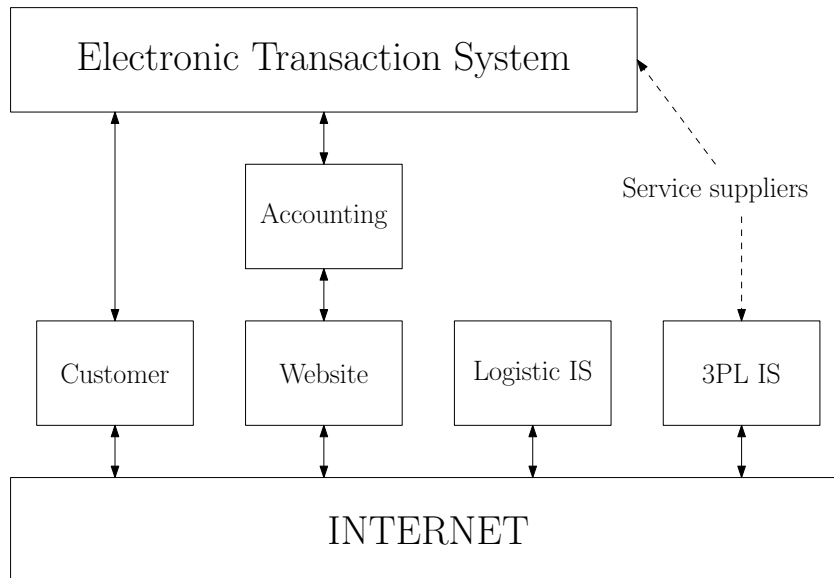

Figure 5: A schematic diagram for the software and systems being involved in the order placement and order fulfillment processes. Each arrow corresponds to the direction of information flow. In this diagram, the flow of the physical product has been omitted.

- (a) How to ensure that the logistic center has sufficient stock of the products for the customers?
- (b) How could it be possible to let the website, the logistic center information system and the 3PL information system exchange information without error?
- (c) If the items received by the customer are different from the items list in the order, which step(s) in the order placement process and/or order fulfillment process might have something wrong?
- (d) If online payment is not allowed, how do you modify the steps in the above processes?

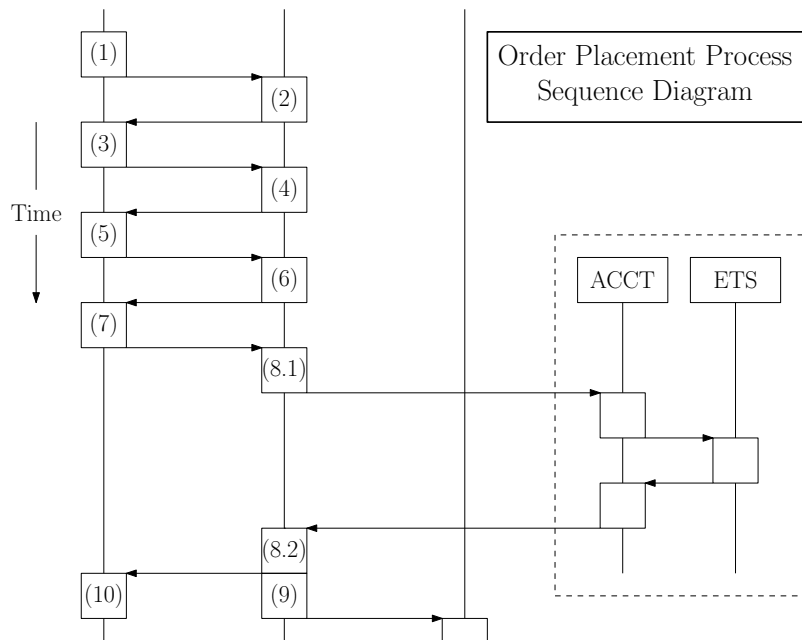
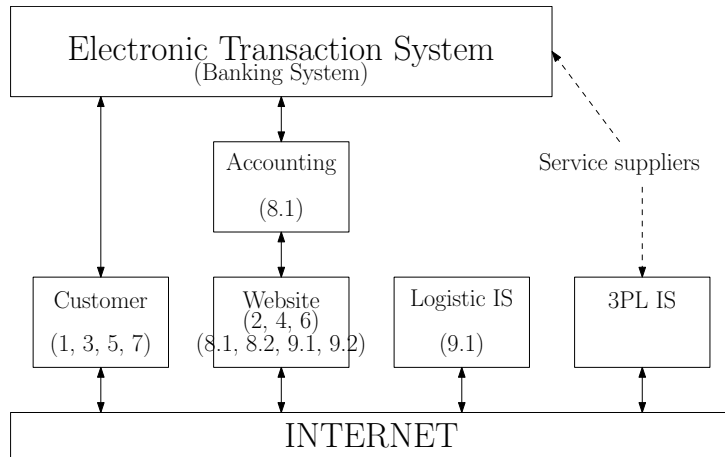

Figure 6: Sequence diagram of the order placement process.

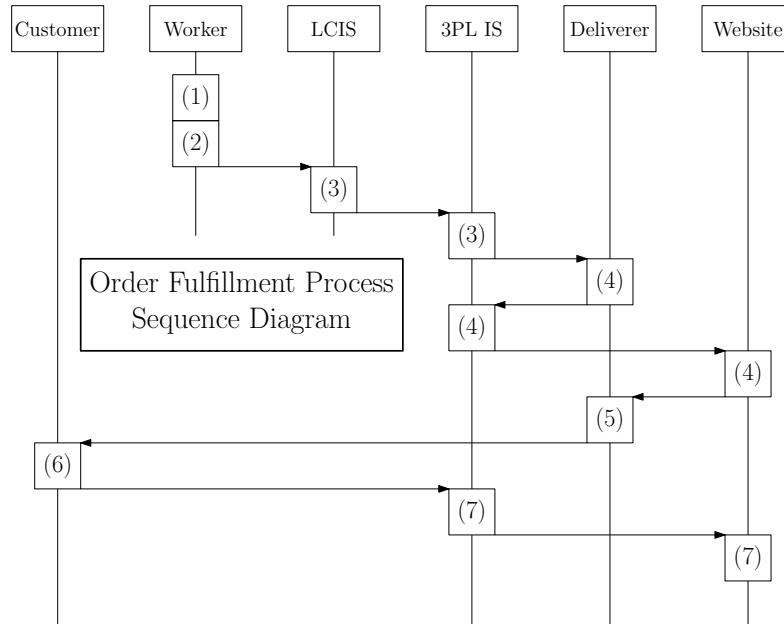
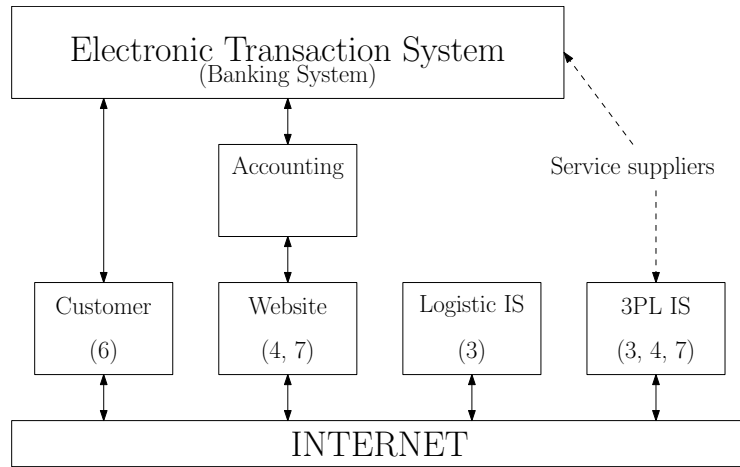

Figure 7: Sequence diagram of the order fulfillment process.

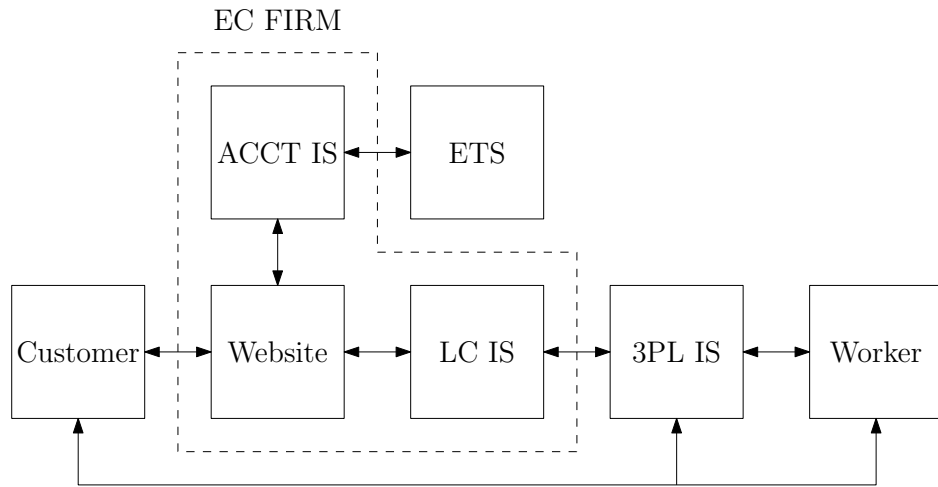

Figure 8: An actor network diagram for the order placement and fulfillment processes.

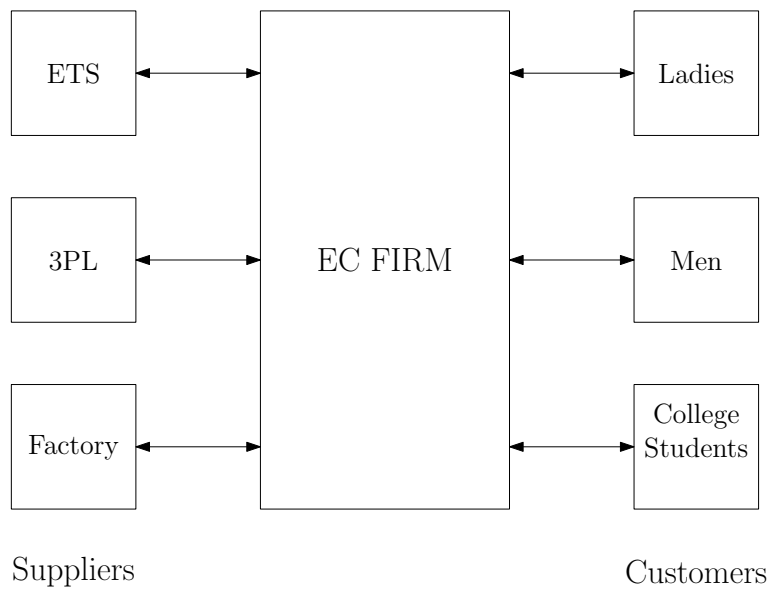

Figure 9: The business model of an EC firm selling fashions for ladies, mens and college students online.

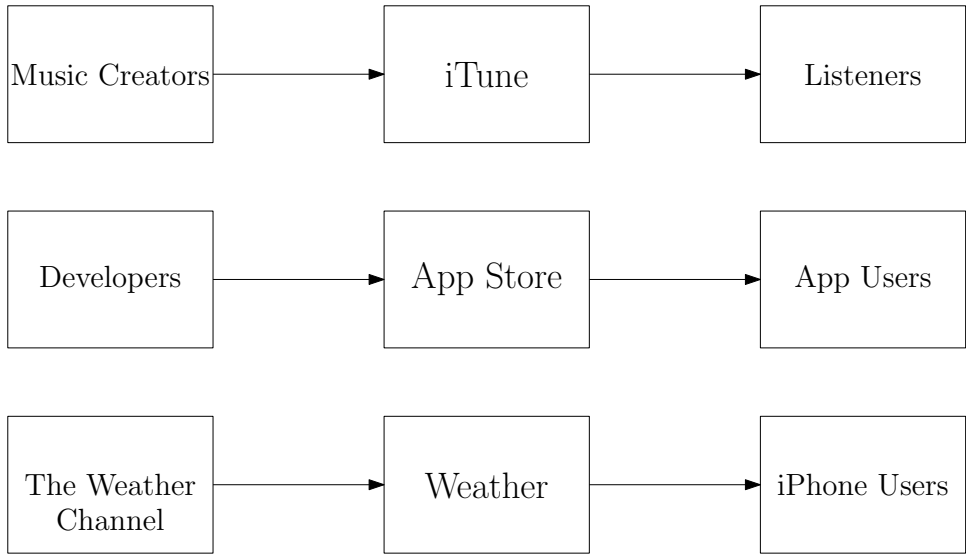
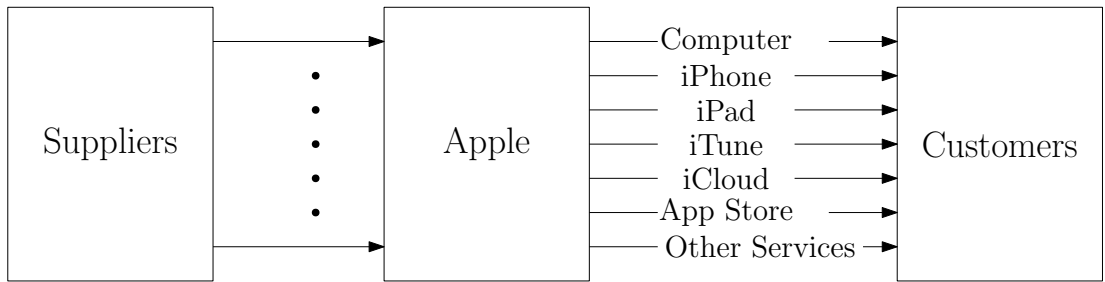

Figure 10: The business model of Apple could be considered as a B2C model. Apple sells both *physical goods* and *electronic goods*. Physical goods include computers, iPhone, iPad, iWatch and Apple Glass. Electronic goods include Safari and Pages, which are free of charge. Electronic goods are also manifested in form of services, such as Apple Map and Weather. Customers need to download and install the corresponding software for using such services.